

Diesel (non turbo) cooling system

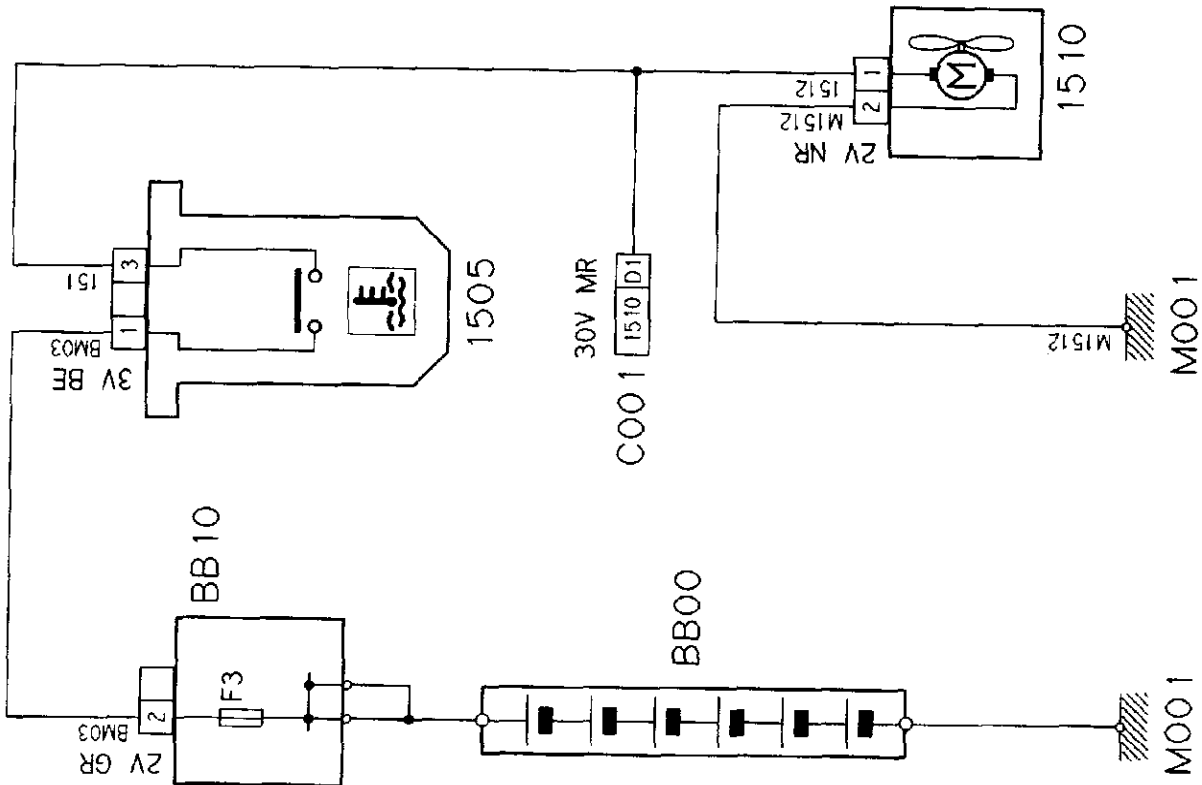

Typical XU5/XU7/XU10J2 cooling system

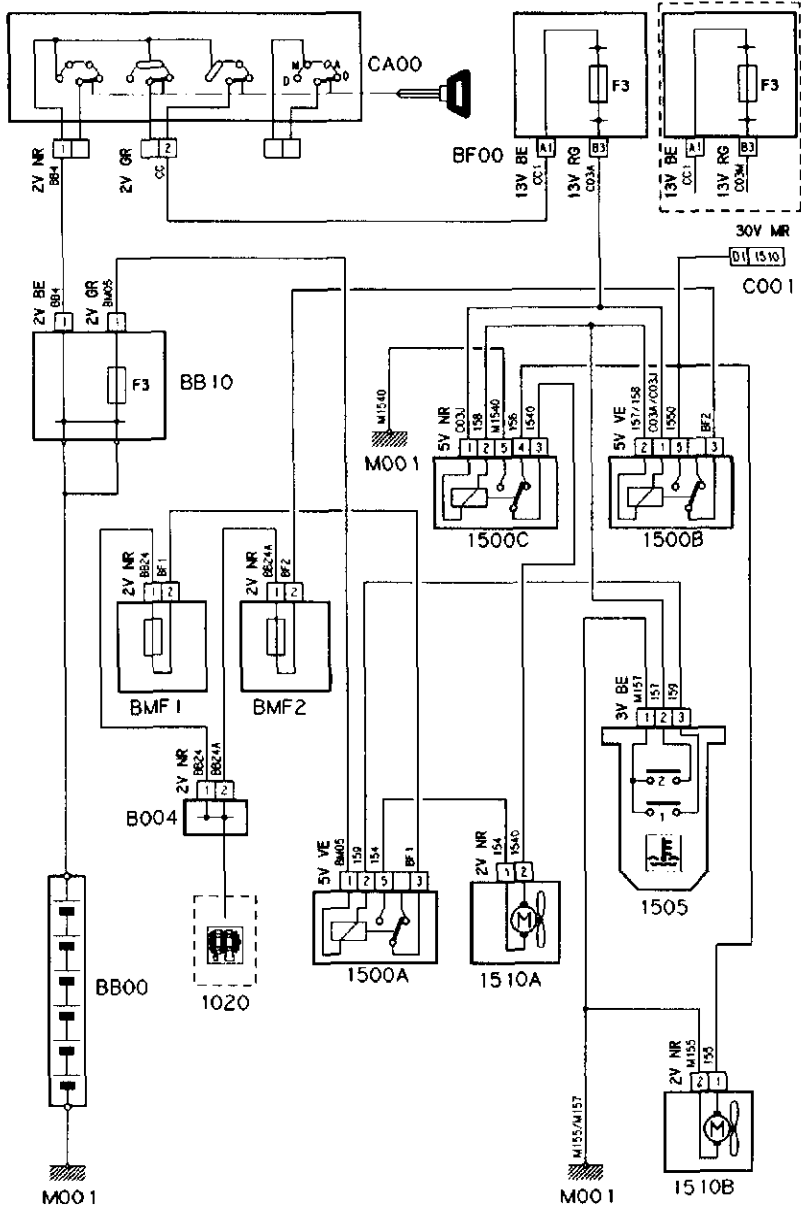

Turbo Diesel cooling system

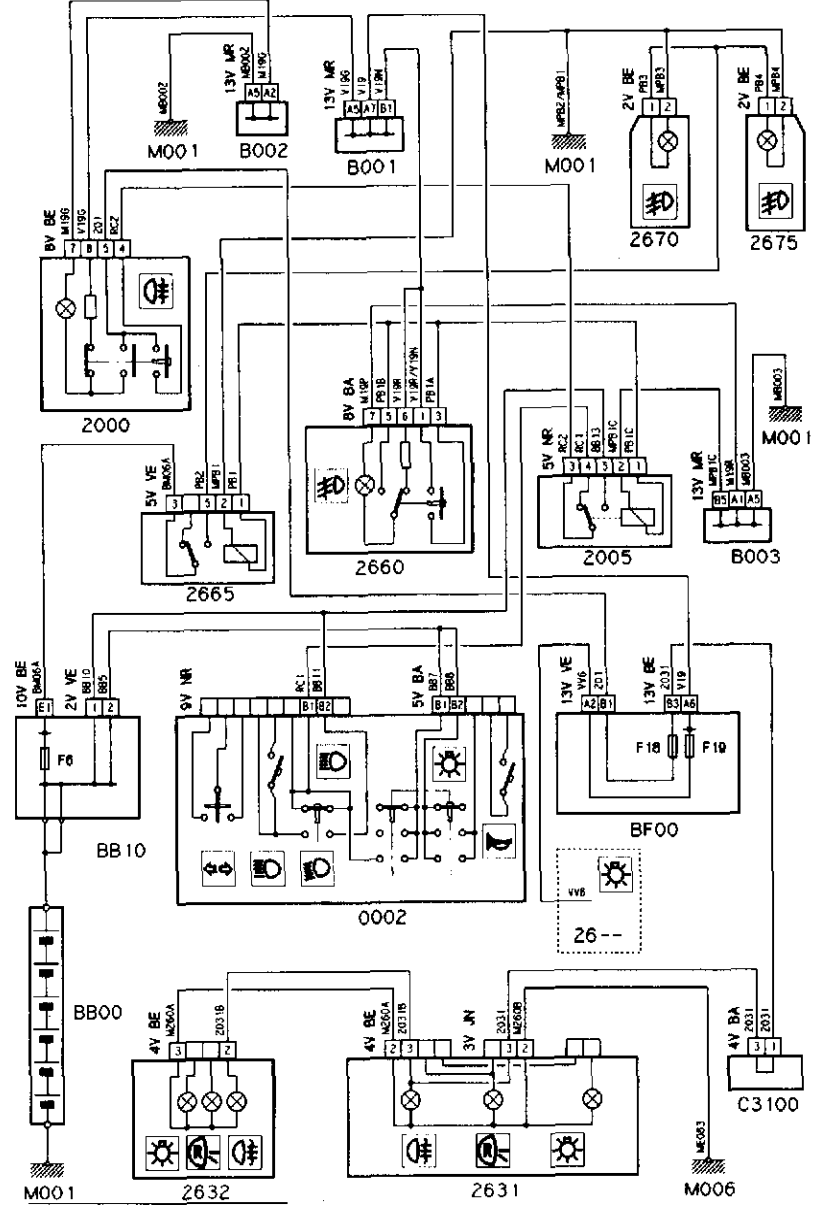

Front/rear foglights

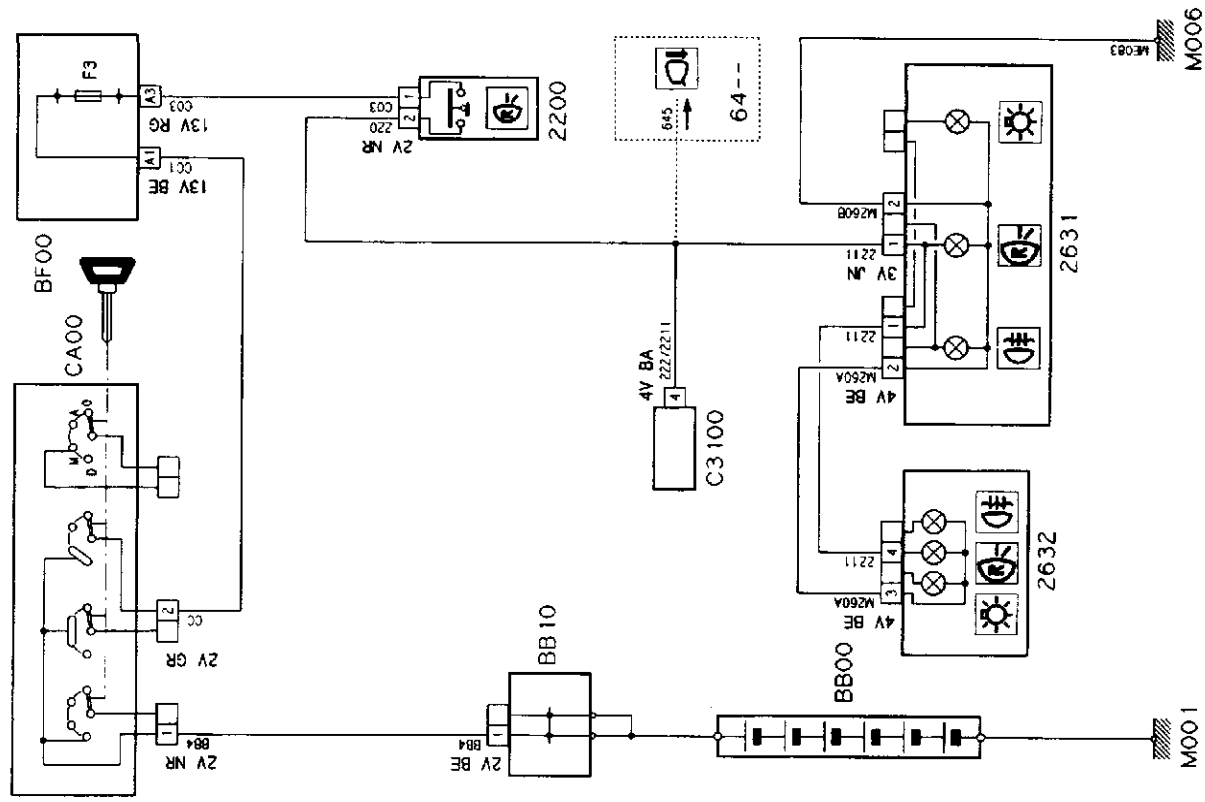

Reversing lights (manual gearbox)

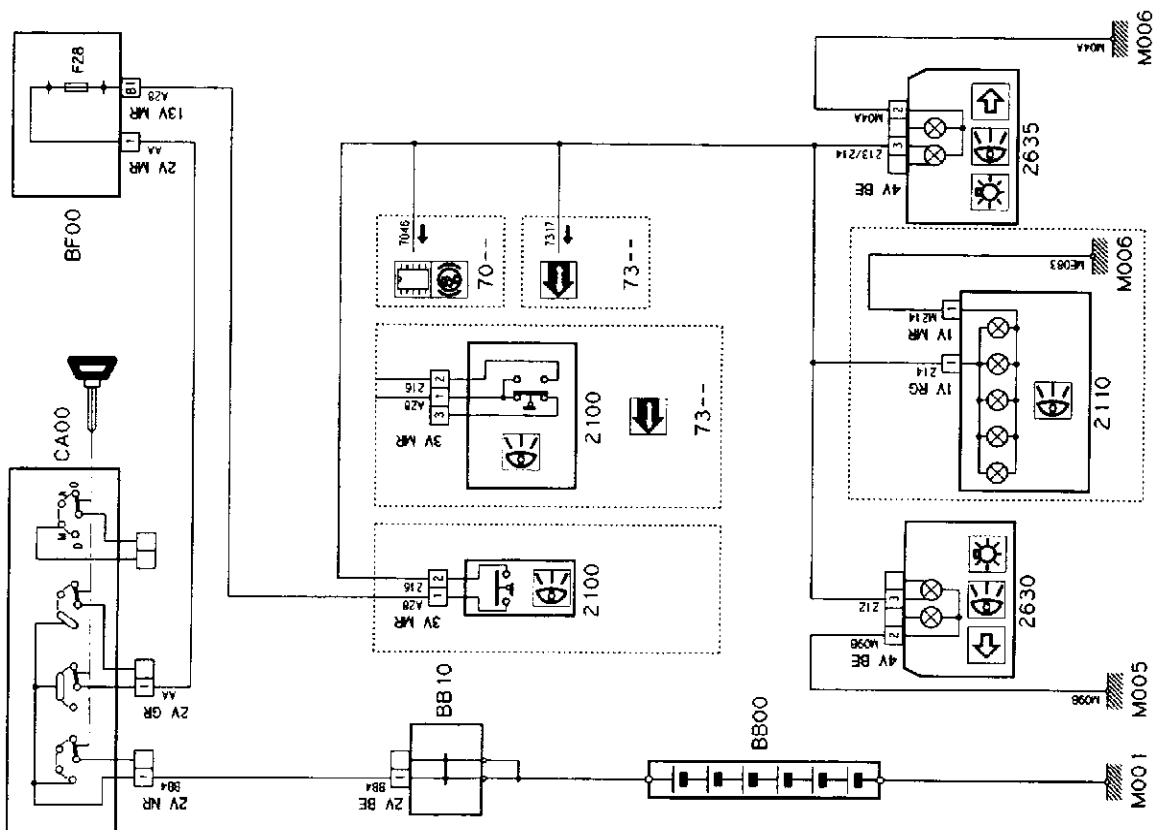

Stoplights

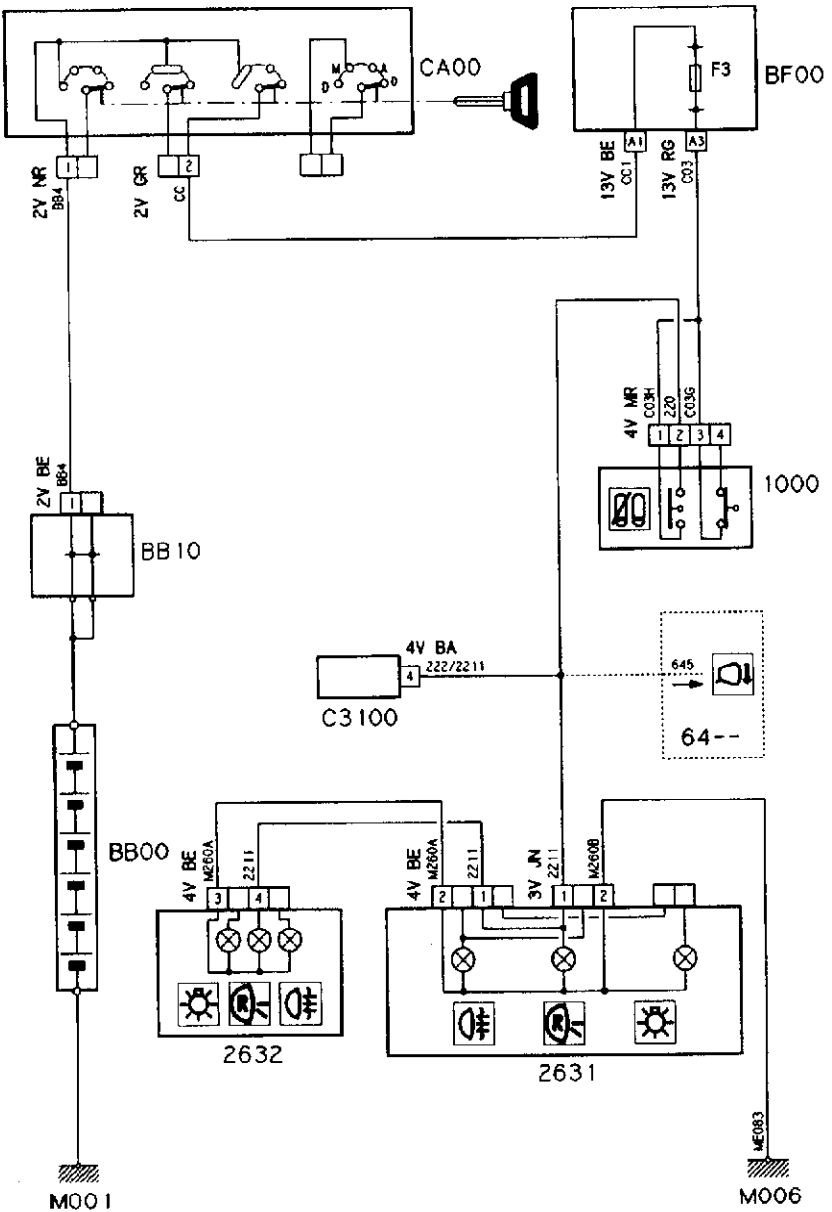

Reversing lights (automatic gearbox)

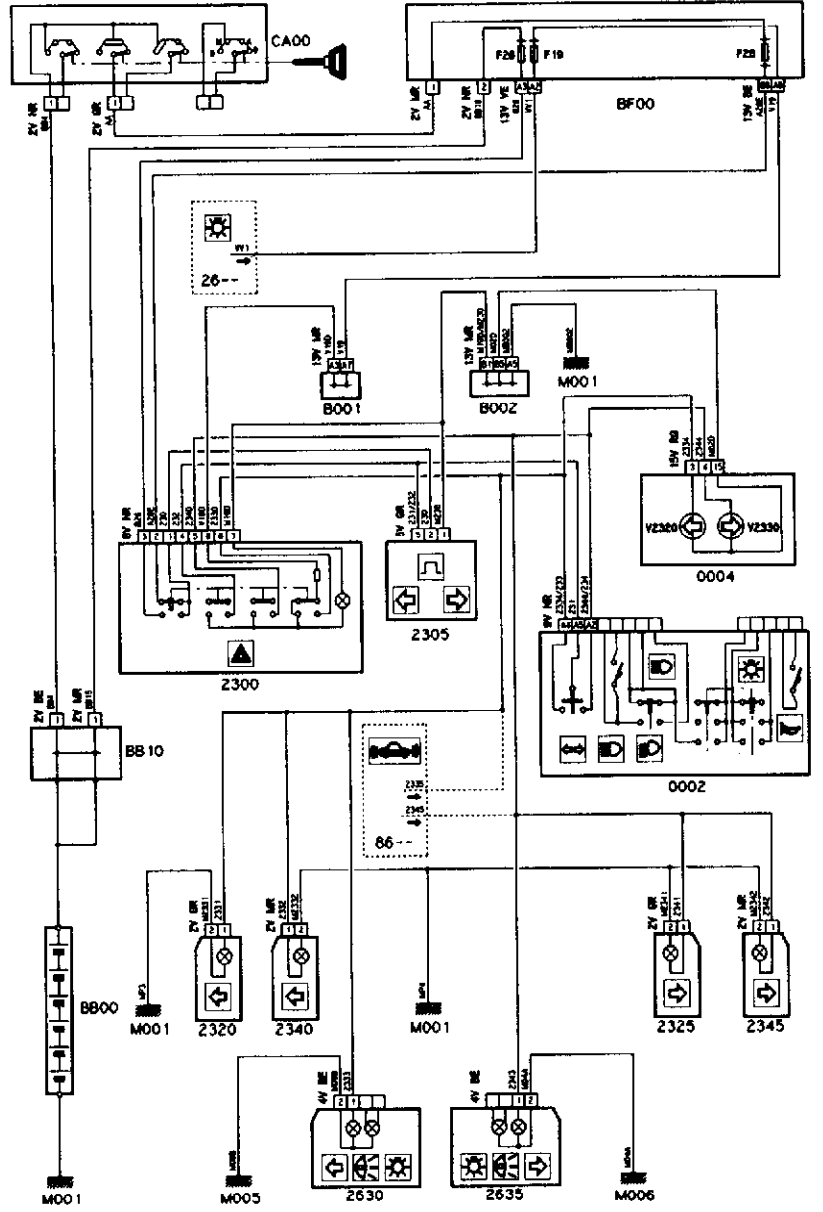

Direction indicators and hazard warning lights

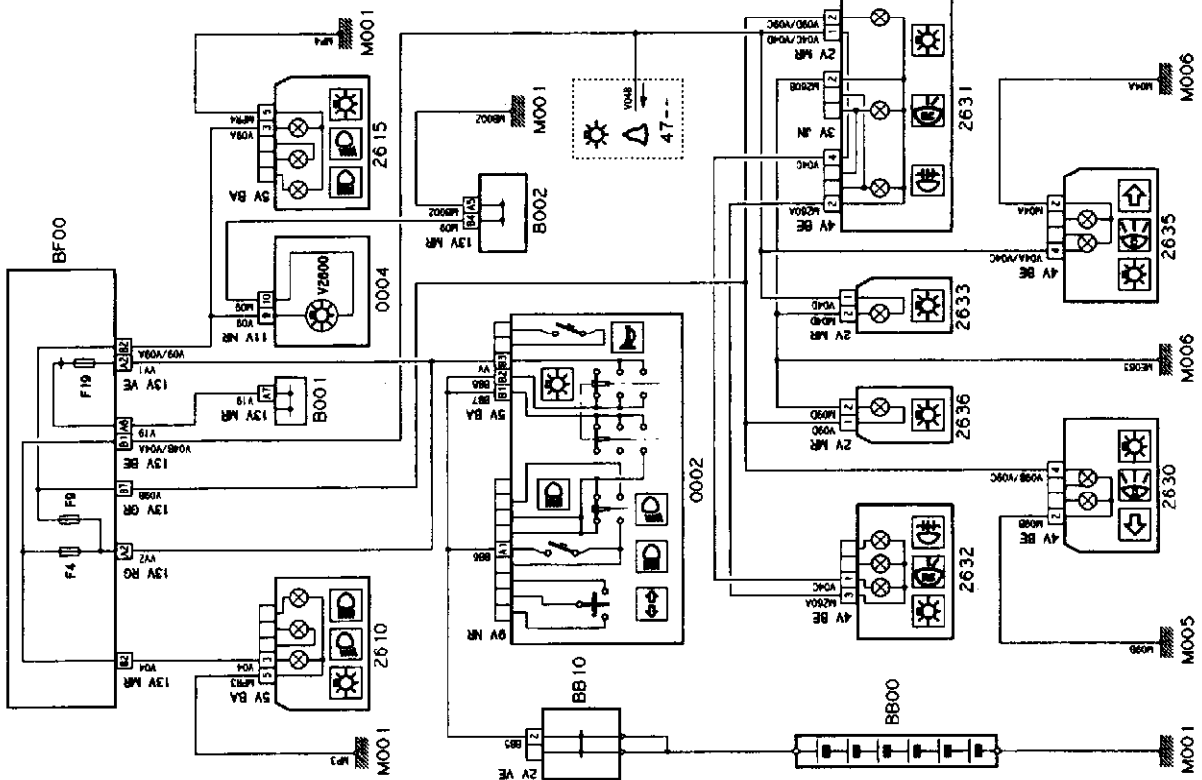

Side and tail lights

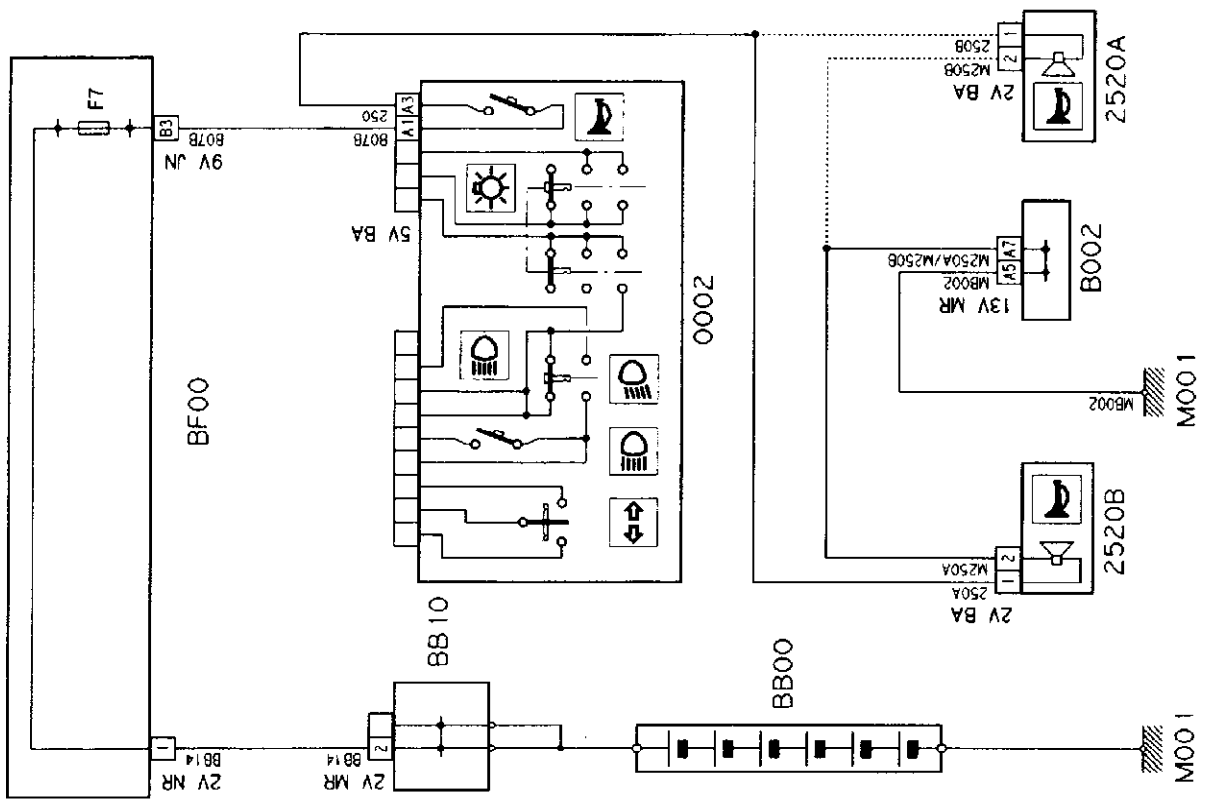

Horns